

No. 682,606.

Patented Sept. 17, 1901.

C. E. DURYEA.
EXPLOSIVE ENGINE FOR MOTOR VEHICLES.

(Application filed July 20, 1897.)

(No Model.)

4 Sheets—Sheet 1.

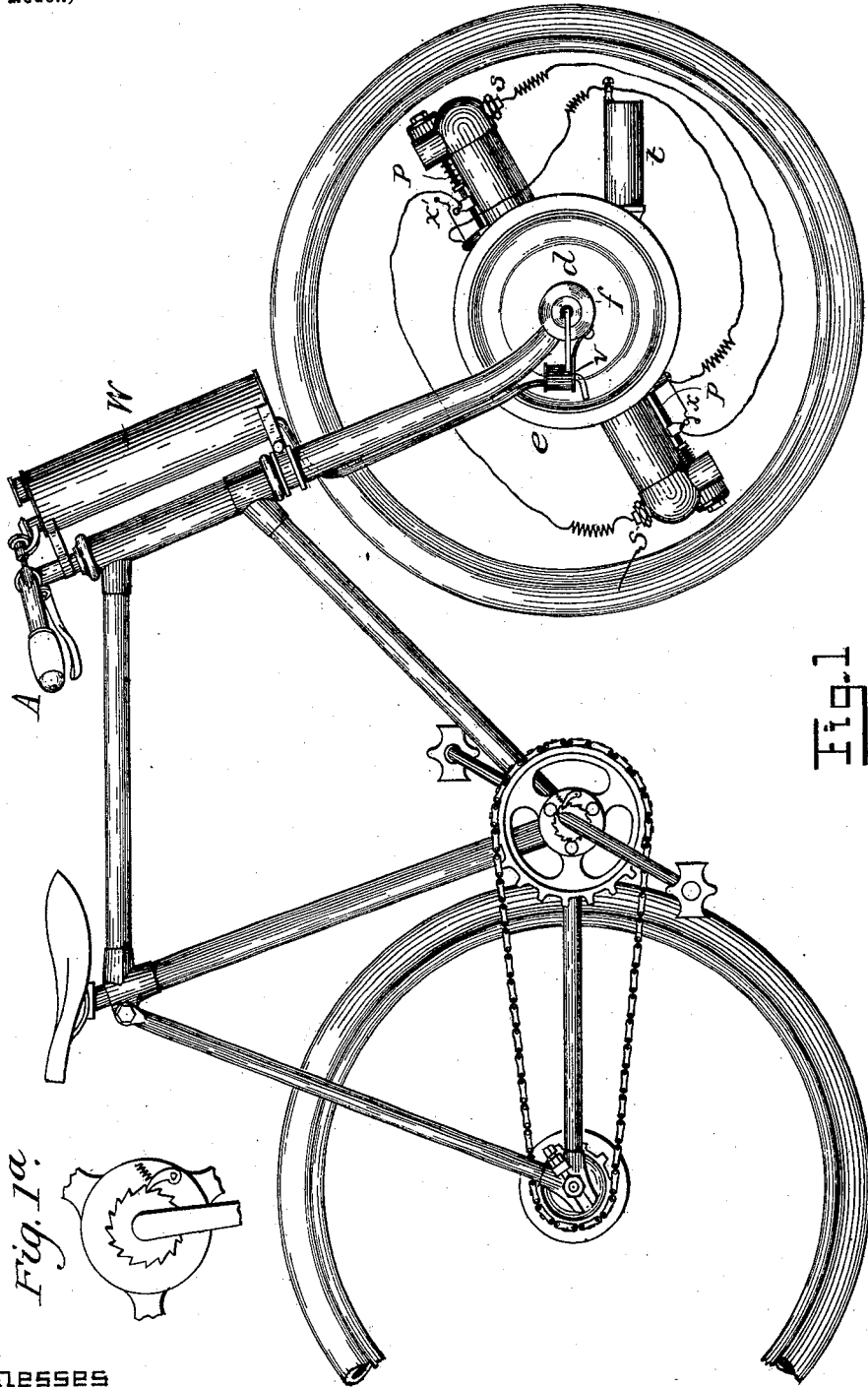
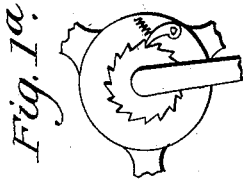

Fig. 1



Witnesses

Stephen D. Dobbins.
Max Guilford

Inventor
Charles E. Duryea
by his atty
Edw. Steale

No. 682,606.

Patented Sept. 17, 1901.

C. E. DURYEA.
EXPLOSIVE ENGINE FOR MOTOR VEHICLES.

(Application filed July 20, 1897.)

(No Model.)

4 Sheets—Sheet 2.

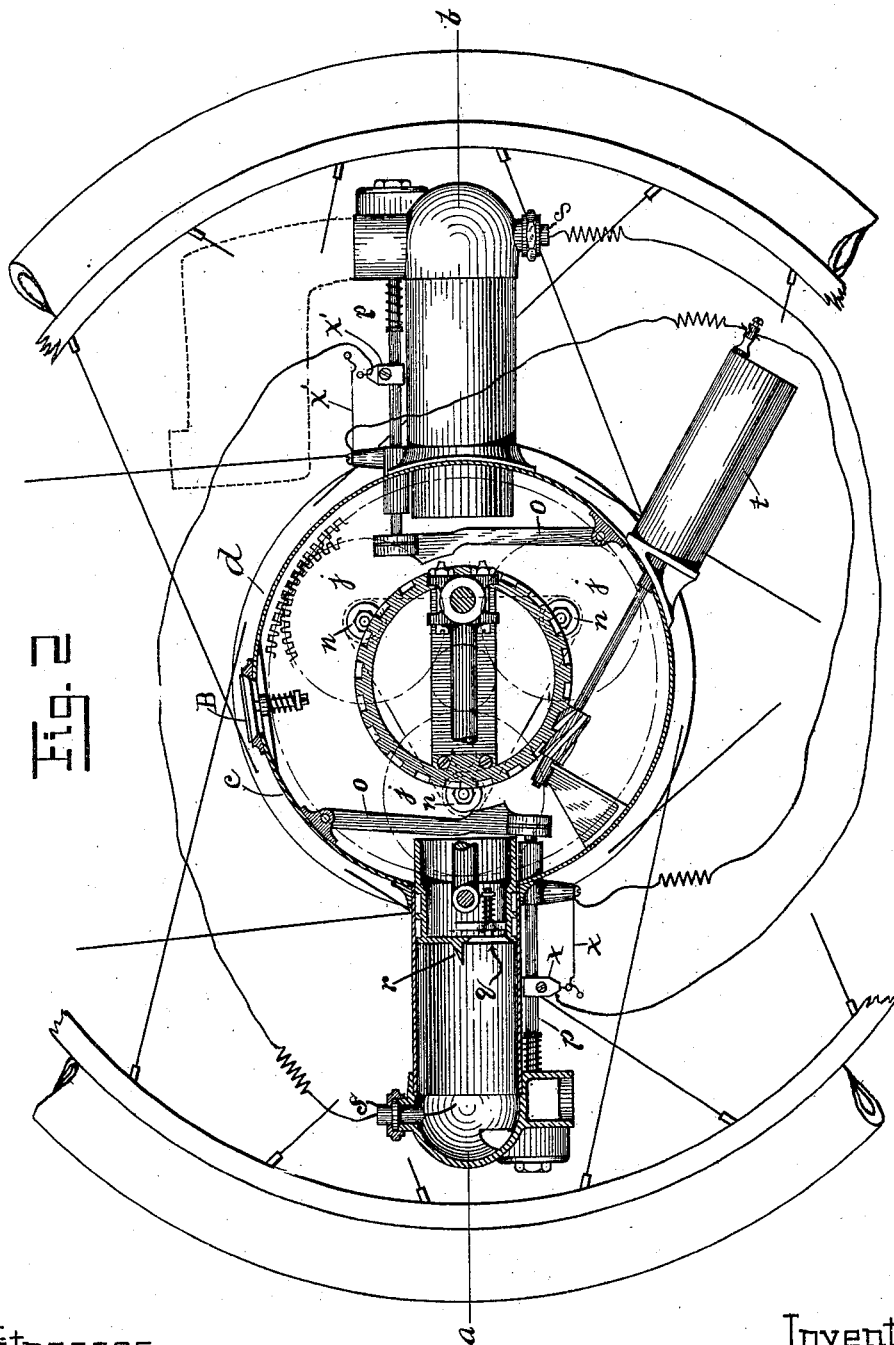

Fig. 2

Witnesses

Stephen D. Dobbins.

Mac Guilford

Inventor

Charles E. Duryea
by his atty
Edw. Keale

C. E. DURYEY.
EXPLOSIVE ENGINE FOR MOTOR VEHICLES.

(Application filed July 20, 1897.)

(No Model.)

4 Sheets—Sheet 3.

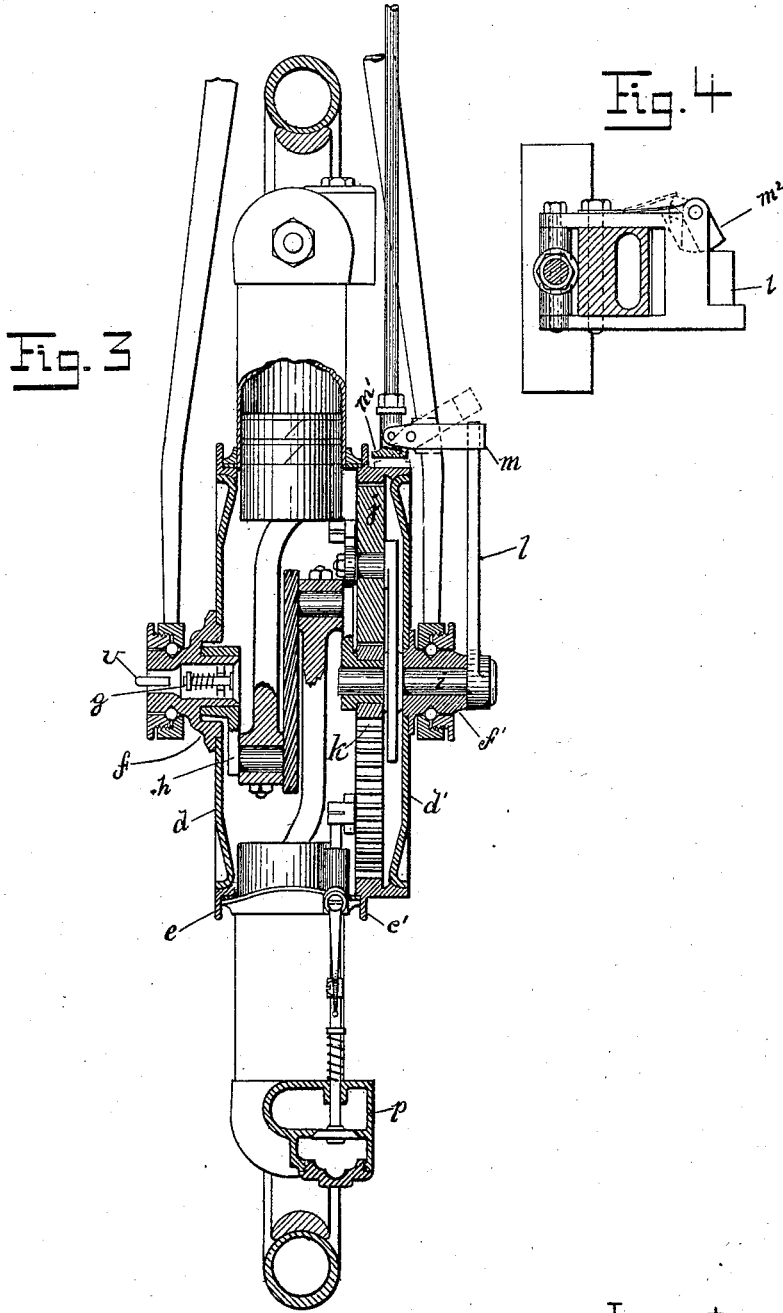

Witnesses

Stephen D. Dobbins.

Mar Guilford

Inventor

Charles E. Duryea
by his atty

W. H. Steale

C. E. DURYEY.
EXPLOSIVE ENGINE FOR MOTOR VEHICLES.

(Application filed July 20, 1897.)

(No Model.)

4 Sheets—Sheet 4.

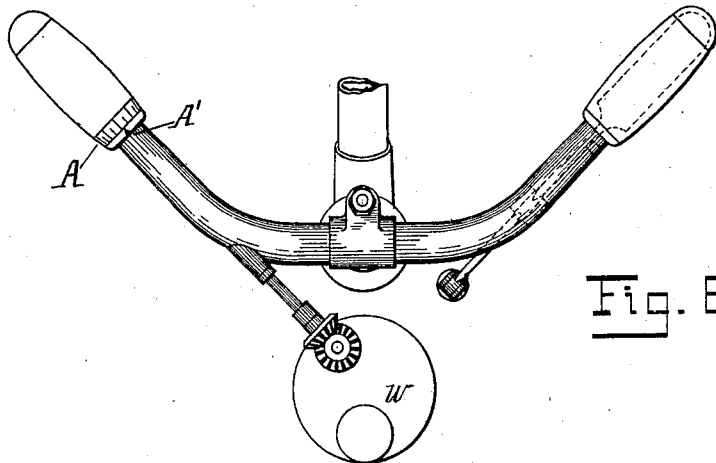

Fig. 6

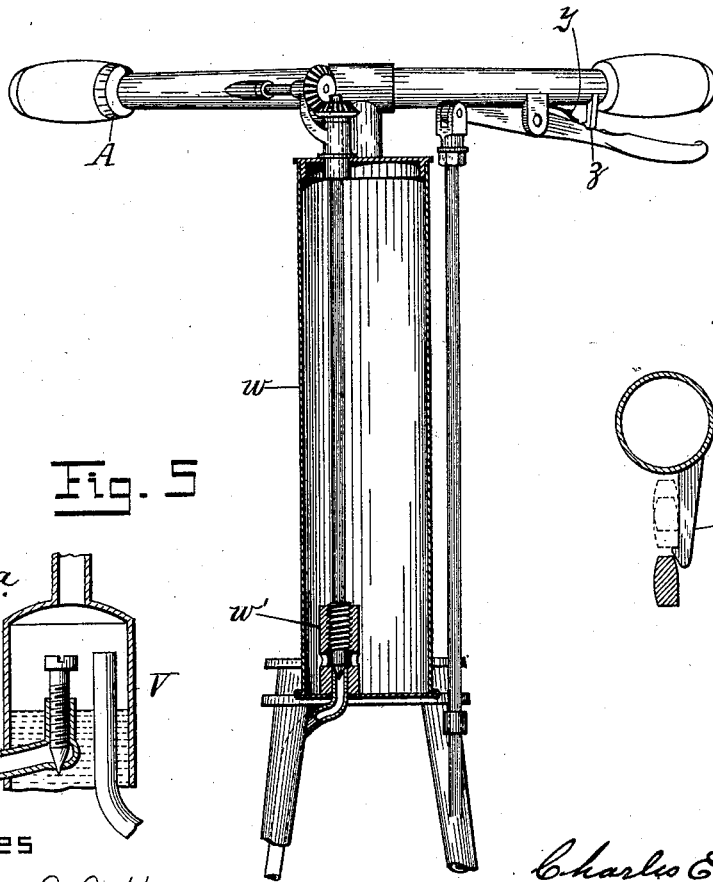

Fig. 5

Fig. 5.a

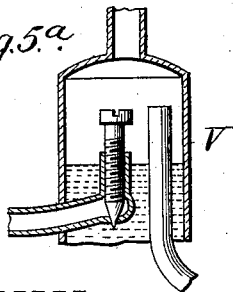
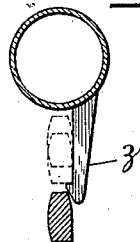

Fig. 7



Witnesses

Stephen D. Robbins.

Max Guilford.

Inventor

Charles E. Duryea
by his atty

C. E. Duryea

UNITED STATES PATENT OFFICE.

CHARLES E. DURYEA, OF ELIZABETH, NEW JERSEY.

EXPLOSIVE-ENGINE FOR MOTOR-VEHICLES.

SPECIFICATION forming part of Letters Patent No. 682,606, dated September 17, 1901.

Application filed July 20, 1897. Serial No. 645,233. (No model.)

To all whom it may concern:

Be it known that I, CHARLES E. DURYEA, a citizen of the United States, formerly of Peoria, Illinois, but now temporarily a resident of Elizabeth, in the county of Union and State of New Jersey, have invented certain new and useful Improvements in Motor-Vehicles; and I do hereby declare that the following is a full and clear description of the invention, which will enable others skilled in the art to make and use the same, reference being had to the accompanying drawings, which form a part of this specification, and in which—

Figure 1 is a side elevation of a motor-bicycle embodying my invention. Fig. 2 is a side elevation and detail illustrating the motor in position in a wheel. Fig. 3 is a cross-section detail about on line *a b*, Fig. 2. Fig. 4 is a detail of the clutch used to connect the motor with the vehicle. Fig. 5 is a front elevation of the controlling-handles and fuel-tank. Fig. 6 is a plan view of same; and Fig. 7 is a detail of the brake-lever controller, while Fig. 1^a is a detail view of common crank-axle ratchet, and Fig. 5^a is a detail of tank *v*.

Similar letters refer to similar parts throughout the several views.

My invention relates to improvements in that class of motor-vehicles commonly used for the conveyance of passengers—that is to say, vehicles of light weight, therefore requiring small power—more particularly such vehicles as bicycles and tricycles, and for the purposes of this description I have shown same as constructed in bicycle form.

The objects of my invention are to secure a light and compact motor suitably placed to prevent accidental damage, easily attended to and operated, capable of use alone or as an auxiliary—a motor of the explosion type having no water-jacket and having most of its moving parts housed to permit lubrication and prevent injury from dirt. These and minor objects, as will appear in this description, have been sought for and attained by this invention, which to this end consists in the construction, arrangement, and combination of parts, as hereinafter more fully described and claimed.

The bicycle shown in Fig. 1 has a frame similar to that in common use, with the exception of the handle-bars, front forks, and

such slight changes as may be needed to accommodate a motor-starting mechanism. This starting mechanism may be of several forms, but is preferably made by using the regular pedals, cranks, sprocket wheels and chain of the ordinary bicycle, in combination with a ratchet or similar device, which permits the free running of the wheel at will. By the use of the ratchet the bicycle or bicycle and motor may be started, and when the motor begins to operate the feet of the rider may rest upon the pedals without movement, allowing the motor to do the work. No description of this ratchet or other device is here given, because such devices are well known, there being many forms of ratchets and several two-speed gears in common use. Some device of this kind, however, is a practical necessity, because of the fact that all explosion-engines must be started in some manner before they will operate.

In Figs. 1, 2, and 3 is shown the motor and its driving mechanism, with its attachment to the bicycle. The motor has one or more cylinders mounted upon the enlarged hub of the wheel, preferably the front wheel, in which enlarged hub is located the crank-shaft and driving machinery. This hub consists of a barrel *c*, having heads *d d'* and flanges *e e'*. This barrel, with its heads, flanges, and other fittings, is practically gas-tight, and its heads are provided with central bearing-pieces *f f'*, of which *f* has an air-passage through it, closed by the valve *g*, opening inwardly, and kept in its closed position by a light spring. It also provides a gudgeon or stud, on which one end of the crank-shaft *h* is journaled. This crank-shaft is suitably cranked to accommodate the given number of pistons and cylinders used, in this case two in number. The other bearing-piece *f'* likewise has a passage through it, which fits the idler-shaft *i*. The inner end of this shaft carries a disk or triangle, on which are mounted idle gears *j j j* and an end of the crank-shaft *h*, with its attached driving-gear *k*. Attached to the flange *e'* or formed integral therewith is an internal gear, into which the idlers *j j j* mesh. On the outer end of the shaft *i* is placed a wheel or lever *l*. On the fork or framework is placed a clutch *m*, arranged to engage and hold the

lever l . On the same studs as the idlers $j j j$ are placed rollers $n n n$, adapted to contact with the levers $o o$ and operate the valve-stems $p p$. Opening through the pistons from the barrel into the cylinders are valves q , similar in action and construction to the valve g . On the piston-heads arise sparker-points r , and in the cylinder-heads are insulated sparker-points s . A dynamo t , driven by spiral gear attached to the crank-shaft, is wired from one pole to the sparker-points $s s$ and connects from the other pole through the machinery with the points r .

Projecting into the opening of the bearing-piece f is a small pipe v , leading from a tank v , Fig. 1. This pipe is of such size as to permit a maximum charge of fuel to flow through it and may either be made of this size or provided with some sort of adjustment.

The tank v is of such size as to contain two or three charges of fuel and is provided with an overflow-pipe which serves to allow any excess of fuel to flow upon the ground and to allow air to enter the tank v to replace any fuel drawn therefrom.

The tank v is filled by gravity from the main supply-tank w , placed upon the head of the machine. This tank is provided with a needle-valve, connected by suitable mechanical means with one of the handles, by which the amount of gasolene flowing to the tank v and available for use by the engine may be regulated. The needle-valve w' is operated from the handle by a set of bevel-gears and suitable shaft, as shown in Figs. 5 and 6. Near the other handle is placed a lever which controls both the clutch m and the brake m' , attached to bear against the extended surface of the flange e' . (See Fig. 3.) This lever is maintained in a position to cause the clutch m to engage the lever l by a spring, shown at y' , and when desired to run the vehicle without the motor the clutch m may be disengaged by drawing the lever-handle toward the bar-handle and permitting the hook z to engage and retain same. This motor is of the Beau de Rochas or four-cycle type most commonly used, and its operation is as follows: The rider mounts the bicycle and starts both bicycle and motor by applying power to the pedals. With the outward motion of the pistons air is drawn through the valve g , and a small portion of gasolene from the tank v is drawn in with the air in the form of a finely-divided spray. With the return of the pistons this mixture, or part of it, passes through the valves q into the cylinder-heads. One of these portions is then compressed by the outward movement of the pistons, the other exhaust-valve being opened by one of the rollers n . At the end of the outward movement this exhaust-valve closes and also closes the sparker-circuit at the points $x' x'$, and since at this position the point r is in close proximity to the insulated point s a high-tension spark will jump from one to the other and fire the mixture, which,

being expanded, drives the piston forcibly back and furnishes power to the crank-shaft. At the next rotation the other piston fires and the alternating motion is continued. Control of the motor is maintained by regulating the amount of gasolene the engine is permitted to draw from the tank v , dependent on the gasolene-level therein. Since the lever l is held in a fixed position it is plain that the idlers $j j j$ must remain in fixed positions, and that power applied to the small gear of the crank-shaft will drive the large internal gear in a direction the reverse of the crank-shaft motion. As shown here, six revolutions of the crank-shaft produce one revolution of the internal gear, and since this internal gear is attached to the flanges and barrel it is evident that these parts must revolve also.

To the flanges $e e'$ spokes are attached which carry the rim and tire. By this arrangement the wheel, with its large hub, the cylinders, and dynamo, revolve as a unit. This revolving increases the speed with which the cylinders travel through the air and so increases the cooling effect and permits the use of small-sized engines large enough for the work, to which they are applied without a water-jacket. By this arrangement the gearing and, in fact, all moving parts except the exhaust-valves are housed and protected from dirt, while the spokes protect the cylinders and such parts from injury.

It will probably be found preferable to start the cycle without the motor just as an ordinary cycle is mounted and started, leaving the motor and machinery free to revolve with the wheel. This can be done by raising the controlling-lever until it is caught and held by the hook z , which throws the clutch m out of engagement with lever l and leaves the motor inoperative. Then after the rider has seated himself and is secure in his balance and the bicycle has some momentum the lever may be so manipulated as to cause the clutch m to engage the lever and stop its forward motion. This at once starts the pistons and draws in and compresses a charge of fuel. Since this compression requires considerable power the momentum of the bicycle will be found helpful, and in cases where this is not sufficient and where the pedals come upon the dead-centers it may be necessary for the rider to take advantage of the ratchet-driving device and oscillate the pedals backward and forward a time or two in the position which gives them the most leverage. By so doing sufficient power can be applied to overcome the resistance of the motor in its initial compression. It is a well-known fact that the motor when cold will not start so readily as when warm, and it may be necessary to continue the starting effect beyond the starting charge, in which case the momentum of the bicycle is rapidly used up and the power of the rider must be depended upon. It will readily be seen that failure would probably

result from the use of cranks if directly applied as in the bicycle because of the necessity of passing the dead-centers, whereas by the use of the ratchet a downward stroke can be made with one foot, followed immediately by lifting the pedal and making another downstroke, thus having no dead-centers except the slight movement required to lift the feet for a new push and having at all times the crank in its most effective position. Consequent upon the expansion of the gases, due to firing, the lever l attempts to move in the reverse direction and must be maintained from doing so by pawl m^2 . This pawl yields out of the way as the lever engages the clutch m and immediately falls in behind the lever, so as to prevent disengagement.

Fig. 4 is a top view showing the end of lever l . The clutch is thrown upward and off the end thereof, as shown by dotted lines in Fig. 3. The lever l is used because it lies close to and parallel with the bicycle-fork and does not add much to the weight or clumsy appearance of the device.

I use, preferably, for firing purposes a small dynamo or friction electric machine and so wired that one is sufficient to do the work, although, if preferred, one may be used for each cylinder. As before stated, the dynamo-shaft and the motor machinery form the connection for one pole of the dynamo, while the other is wired from the dynamo to the circuit-making points $x' x'$ of one cylinder and thence to the sparker r on the other. It is the intention to fire the charge slightly before the dead-center is reached, and at this time the exhaust-valve of the opposite engine is closing and in its downward movement it closes the circuit at the points $x' x'$ and permits the spark to jump from the sparker-point s to the corresponding point r and ignite the charge. While in this case I have shown spiral gears to drive the dynamo, I do not limit myself thereto, but may substitute any well-known means of conveying motion from the motor to the dynamo for this purpose. It is usually preferred to allow the exhaust to rush into the open air with its accompanying bark or noise; but, if preferred, a muffler can be adopted, which will reduce the noise, and a muffler has been indicated by dotted lines in Fig. 2.

For purposes of dissecting the parts and of easily getting at them for inspection the heads $d d'$ of the motor barrel or hub are screwed in and are removable after the wheel has been removed from the forks.

On the handle which controls the valve w' is placed a dial A, and a small pointer A' is fixed to the bar, so that the comparative amount of gasolene being fed at any time may be seen at a glance. Other arrangements of the controlling valve or mechanism for operating the motor may be used, the object being to effect the steering of the bicycle in the usual manner and to control the motor without releasing the handles, for in using

the motor high speeds will be very common, and at high speeds it is not safe to let go of the handles. By the arrangement shown twisting the handle varies the supply of fuel and, in effect, throttles the motor, as desired. As a further element of safety the lever which controls the clutch m and the brake m' is usually grasped by the other hand without being removed from the other handle, so that in fact two safeguards against possible run-aways or loss of control are provided.

The barrel or chamber in which the crank-shaft is placed is made strong enough to withstand any premature explosions therein, but such an explosion would leave a pressure and interfere with several following charges, and so to prevent this or largely destroy its effect a relief-valve B, opening outwardly, is provided.

It is customary in explosion-engines to provide them with fly-wheels, which by storing momentum carry the engine over the non-working strokes and enable it to compress a charge for the next working stroke. Such fly-wheels add more or less weight, which is of no advantage if the purpose of the fly-wheel can be served in some other manner. This I attain by using the engine casing and cylinders with the wheel rim and tire as a fly-wheel. It may be added that the momentum of the bicycle serves to some extent the same purpose; but it is preferred not to depend upon this, and so the gearing has been arranged in such manner that the engine itself and the wheel in which it is placed serve as fly-wheel, as before stated.

While I have shown the reservoir for fuel as placed on the steering-head of the machine over the front wheel because it is least objectionable there, it is quite evident that the same may be placed anywhere on the frame of the vehicle high enough to get a gravity flow toward the engine.

It is common practice to run stationary engines at normal speed; but locomotives must vary in speed to suit the various requirements, and for this reason the common dynamo cannot be directly connected with the motor, but is used in connection with a governor, which insures practically a fixed speed to the dynamo irrespective of the speed of the motor. I use an electric generator having such a wide range of speeds that it may vary as does the motor and so may be directly connected to the motor. The value of this direct connection is as follows: first, no governor is needed, and, second, the high-voltage spark will jump farther as the speed is higher.

The sparking-point r of the piston is tapered, and as the piston moves toward the sparking-point s the metal body of the point r approaches the point s as the dead-center of the crank-shaft is reached. At slow speeds the low-voltage spark will not jump across the intervening space and ignite the mixture until the nearest point is reached; but at higher speeds the spark will jump correspond-

ingly sooner and ignite the mixture sooner. This is a feature desired, for since the mixture requires some time to burn and expand it should be fired sooner at high speeds than at low ones, and this result is obtained without mechanical means by the proper inclination of the surface of the sparker-point *r* and by the use of a direct connected generator.

I claim—

- 10 1. In a motor-vehicle, a fuel-supply tank located on the front fork portion thereof and provided with an adjustable fuel-supply valve, an inlet-port for the admission of air and fuel concentric with the front wheel and
 15 axis, an inwardly-opening valve closing said port, air and fuel passages communicating with the inlet-port, a combined hub and engine case adapted to receive the fuel mixture and also containing the working mechanical
 20 parts, a crank-shaft, idlers gearing the same to the wheel-hub, an idler-shaft carrying said idlers, a clutch for clutching said shaft at will to the bicycle-forks, said case being provided with cylinders having pistons connected to
 25 said crank-shaft and having outwardly-opening valves.
2. In a motor-bicycle, a tubular bearing-axis having an inwardly-opening valve at the inner end, a crank-shaft bearing concentric
 30 with the passage, a fuel-atomizer so placed as to permit an explosive mixture to be drawn

through the valve, a crank-inclosing case forming the hub of the wheel and supporting-cylinders with pistons attached to the crank-shaft, in combination with idler-gears engaging with the crank-shaft pinion and the crank-case, a pinion on the crank-shaft and arranged to drive the crank-case when the idler-gears are maintained in a fixed position, an idler-shaft passing out of the said case concentric with the wheel-axis and on the opposite side from the inlet-port; a clutch whereby said idler-shaft is adapted to be clutched to the bicycle-forks.

3. In a motor-bicycle, an explosion-engine placed within the front wheel, a crank-shaft, a pinion on said shaft, a fuel-inlet port concentric with the axis on one side of the wheel, an idler-shaft projecting from the inside of the wheel outwardly through the axis on the other side of the wheel, idlers meshing with pinion on the crank-shaft and engaging the crank-case, and means for clutching the idler-shaft and the bicycle-forks, which means are operated by one hand of the rider, combined with means for regulating the fuel-supply by the other hand of the rider.

Witness my hand.

CHARLES E. DURYEA.

Witnesses:

BENJAMIN M. OGDEN,
 S. R. OGDEN.